



TARGET
PACKAGING
SYSTEMS LTD

PRECISION QUALITY RELIABILITY



EUROCHECK - W - SERIES

Automatic Check Weigher Controller

Model FAC-5900



1. 10 inches 16.7M color TFT LCD (resolution: 800x480)
2. Convenient touch screen type
3. Different screen display and graphic display methods
4. Arbitrary selection of absolute value and deviation measurement method
5. Built-in data double back up function in case of blackout
6. Calibration and SPAN auto calibration function
7. Auto zero tracking function
8. 2nd stage gear shift drive possible using inverter (speed 1 & speed 2)
9. Built-in temperature change and noise compensation circuit
10. Weight setting value storage and recall functions for each item (99 items)
11. Printing function <OPTION>: printing possible by connecting to the printer
12. External machine compatible <OPTION>: can connect to different external machine and communication devices
13. Metal detection function <OPTION>: weight and metals are detected simultaneously by installing metal detector
14. Convenient data collection and analysis :
Production status by item can be measured Collected data can be brought up on excel
15. USB memory storage and update :
Stored data of production can be stored in USB drive
Easy update possible using SD memory card
16. Automatic speed change depending on the length of packs
17. Measure the length as products are passing through
18. Metal detector operating time is automatically controlled depending on the production speed
19. Load road cell and balance sensor are used to manufacture at different speeds (from low to high)
20. Can monitor real-time using smartphone application - compatible
21. Complies with current CE average weight legislation

Display Configuration

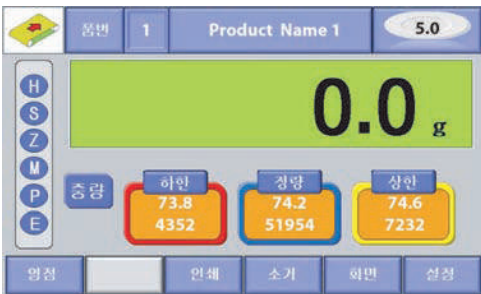

PrinterFormat (option)

(Individual Format)

| Part | Serial No. | Net Weight | Judgement Level |
|------|------------|------------|-----------------|
| 1 | 4 | P | 115 |
| 1 | 5 | P | 115 |
| 1 | 6 | P | 115 |
| 1 | 7 | O | 115 |
| 1 | 8 | P | 115 |
| 1 | 9 | O | 115 |
| 1 | 10 | O | 115 |
| 1 | 11 | O | 115 |
| 1 | 12 | U | 115 |
| 1 | 13 | O | 115 |
| 1 | 14 | P | 115 |
| 1 | 15 | P | 115 |
| 1 | 16 | O | 115 |
| 1 | 17 | P | 115 |
| 1 | 18 | P | 115 |

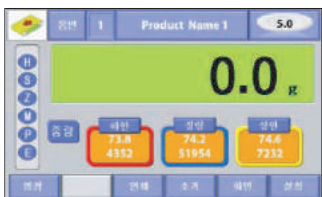

Main Screen



Level Screen

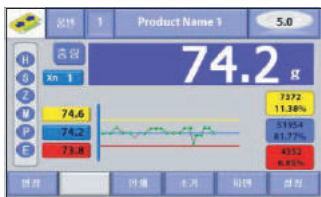

Average Screen

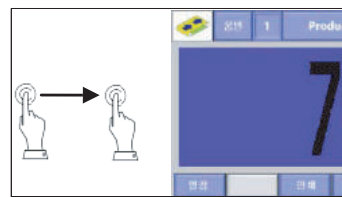

Weight Screen

Automatic Check Weigher Model Guide

W-Series

External Dimensions (unit: mm)

| MODEL | W303 | W313 | W323 | W333 | W343 |
|---------------|-----------------|--------------------|-----------------|-------------|-------------|
| B (BeltWidth) | 100 | 150 | 220 | 300 | 360 |
| C1 | 260/320 /380 | 260/320 380/440 | 320/380 /440 | 450 /550 | 550 /650 |
| C3 | 260/320 /380 | 260/320 380/440 | 320/380 /440 | 450 /550 | 550 /650 |
| L1 | C1+C3+4 | C1+C3+4 | C1+C3+4 | C1+C3+7 | C1+C3+7 |

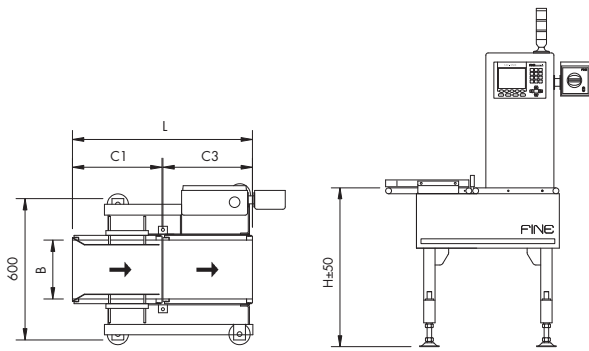

Specifications

| MODEL | | W303 | W313 | W323 | W333 | W343 |
|-----------------------------|----------|--|---|---|---|--|
| (Maximum Capacity) | | 300g | 600g | 1,200g | 3,000g | 6,000g |
| (Weigh Range) | | 3 ~ 300g | 6 ~ 600g | 12 ~ 1,200g | 30 ~ 3,000g | 60 ~ 6,000g |
| (Scale Interval) | | 0.05g | 0.1g | 0.2g | 0.5g | 1g |
| (Maximum Accuracy *) | | ± 0.15g | ± 0.3g | ± 0.4g | ± 1.5g | ± 3g |
| (Maximum Weighing Speed **) | | 400ea/min | 350ea/min | 250ea/min | 100ea/min | 75ea/min |
| (Conveyor Speed) | | 10 ~ 84m/min | 10 ~ 74m/min | 10 ~ 74m/min | 10 ~ 58m/min | 10 ~ 53m/min |
| (Product Size) | (Width) | 30 ~ 100mm | 30 ~ 150mm | 30 ~ 220mm | 30 ~ 300mm | 30 ~ 360mm |
| | (Length) | 30 ~ 200mm | 30 ~ 260mm | 30 ~ 320mm | 30 ~ 450mm | 30 ~ 550mm |
| | (Height) | 10 ~ 100mm | 10 ~ 150mm | 10 ~ 220mm | 10 ~ 300mm | 10 ~ 360mm |
| (Applicable Rejectors) | | R203 Flip Bar R313 Slide Carrier R403 AirBlast R503 Pusher on Belt R703 DropBelt | R213 Flip Bar R313 Slide Carrier R413 AirBlast R513 Pusher on Belt R613 Pusher on Roller R713 DropBelt | R223 Flip Bar R423 AirBlast R523 Pusher on Belt R623 Pusher on Roller R723 DropBelt | R233 Flip Bar R433 AirBlast R533 Pusher on Belt R633 Pusher on Roller R733 DropBelt | R243 Flip Bar R543 Pusher on Belt R643 Pusher on Roller R743 DropBelt |
| (Power Requirements) | | 200VAC ±10%, Single Phase, 50/60Hz | | | | |
| (Environmental conditions) | | 5℃ ~ 35℃ (41℉ ~ 95℉, Variation not to exceed ±2 (4) /hr, %Relative Humidity : 35 % ~ 85 % | | | | |

* Maximum Accuracy may change depending on the product conditions.

** Maximum Weighing Speed may change depending on the product dimension and conveyor speed.

Rejector Model Guide

Flipper Arms

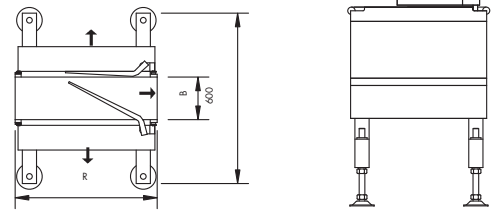
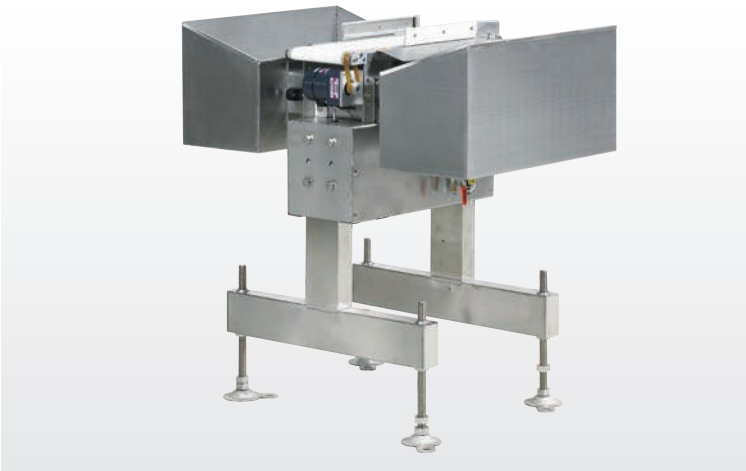

| MODEL | R203 | R213 | R223 | R233 | R243 |
|-----------------------------|----------------------------|----------------------------|--------------------|--------------------|----------------|
| Transportable weight , [kg] | 0.4 | 0.6 | 1.2 | 3 | 6 |
| Max. Reject Count [ea/min] | 130 | 120 | 100 | 60 | 45 |
| Dimensions , [mm] | B:100 R:440/500 /560 | B:150 R:500/560 /620 | B:220 R:620/680 | B:300 R:750/850 | B:360 R:850 |
| Applicable Weigher Model | W303 | W313 | W323 | W333 | W343 |

Air Blast

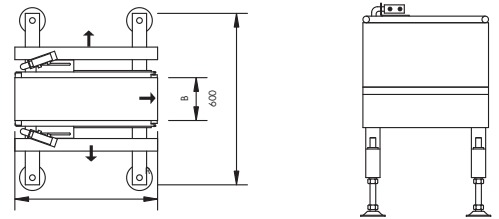
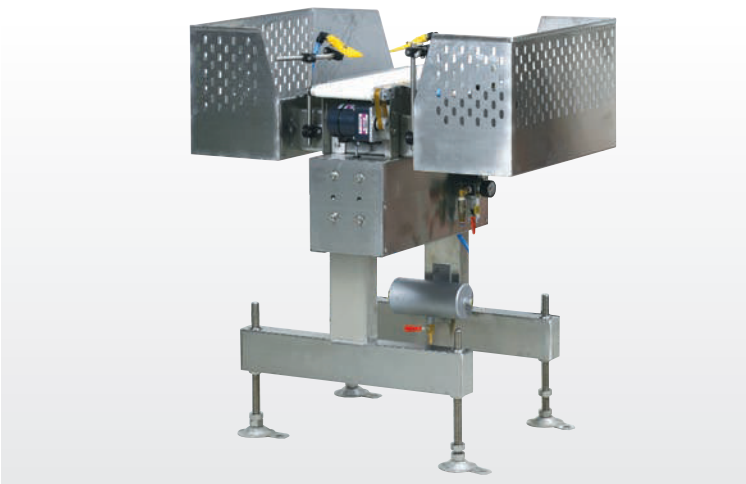

| MODEL | R403 | R413 | R423 |
|-----------------------------|----------------------------|--------------------------------|--------------------|
| Transportable weight , [kg] | 0.4 | 0.6 | 0.6 |
| Max. Reject Count [ea/min] | 400 | 350 | 250 |
| Dimensions , [mm] | B:100 R:440/500 /560 | B:150 R:440/500 /560/620 | B:220 R:440/500 |
| Applicable Weigher Model | W303 | W313 | W323 |

Drop Belt

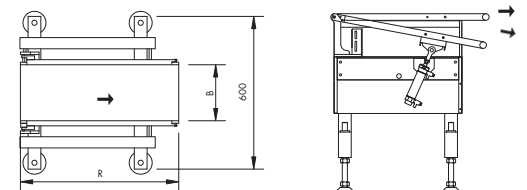

| MODEL | R703 | R713 | R723 | R733 | R743 |
|-----------------------------|------------------------|------------------------|----------------|------------------------|------------------------|
| Transportable weight , [kg] | 0.4 | 0.6 | 1.2 | 3 | 6 |
| Max. Reject Count [ea/min] | 100 | 80 | 70 | 50 | 40 |
| Dimensions , [mm] | B:100 R:440 /500 | B:150 R:440 /500 | B:220 R:440 | B:300 R:450 /550 | B:360 R:550 /650 |
| Applicable Weigher Model | W303 | W313 | W323 | W333 | W343 |

Rejector Model Guide

Slide Carrier

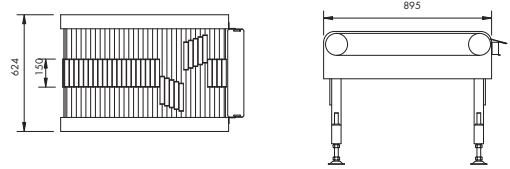

| MODEL | R313 |
|-----------------------------|------------------|
| Transportable weight , [kg] | 0.6 |
| Max. Reject Count [ea/min] | 180 |
| Dimensions , [mm] | B: 150 R: 895 |
| Applicable Weigher Model | W303/W313 |

Pusher on Belt

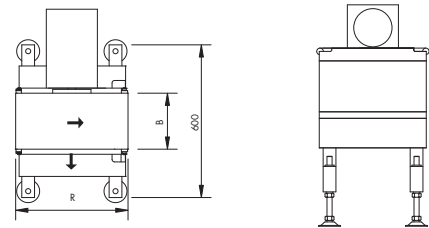
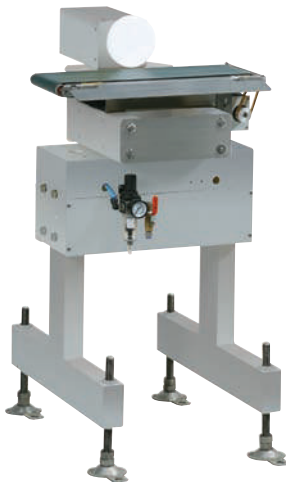

| MODEL | R503 | R513 | R523 | R533 | R543 | R553 | R563 |
|-----------------------------|------------------------|------------------------|------------------------|------------------------|------------------------|------------------------|-------------------------|
| Transportable weight , [kg] | 0.4 | 0.6 | 1.2 | 3 | 6 | 30 | 30 |
| Max. Reject Count [ea/min] | 180 | 150 | 130 | 90 | 80 | 70 | 60 |
| Dimensions , [mm] | B:100 R:440/ 500 | B:150 R:440/ 500 | B:220 R:440/ 500 | B:300 R:450/ 550 | B:360 R:550/ 650 | B:380 R:700/ 900 | B:480 R:900/ 1100 |
| Applicable Weigher Model | W303 | W313 | W323 | W333 | W343 | W353 | W363 |

Pusher on Roller

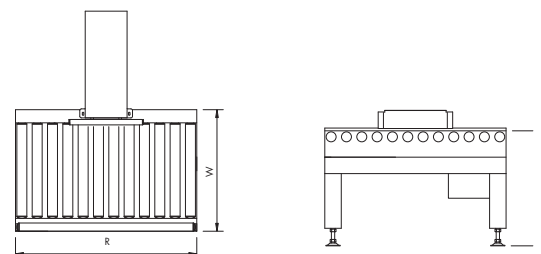

| MODEL | R633 | R643 | R653 | R663 | R673 | R683 |
|-----------------------------|------------------------|------------------------|------------------------|-------------------------|--------------------------|--------------------------|
| Transportable weight , [kg] | 3 | 6 | 20 | 30 | 40 | 60 |
| Max. Reject Count [ea/min] | 80 | 70 | 60 | 45 | 30 | 20 |
| Dimensions , [mm] | W:510 R:450 /500 | W:570 R:550 /650 | W:640 R:690 /914 | W:740 R:914 /1100 | W:840 R:1100/ 1300 | W:940 R:1100/ 1300 |
| Applicable Weigher Model | W333 | W343 | W353 | W363 | W373 | W383 |