

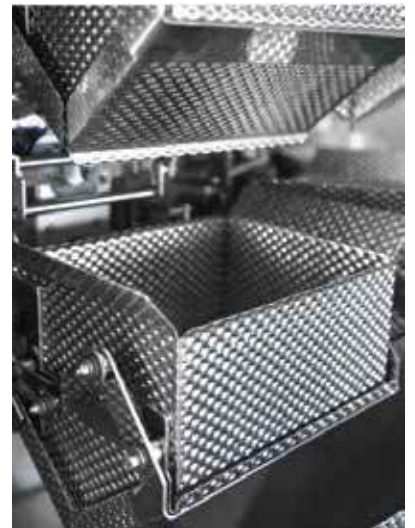

TARGET
PACKAGING
SYSTEMS LTD

PRECISION QUALITY RELIABILITY



Suitable for weighing big products such as potatoes, tomatoes, onions, fruits, vegetables, Meat and Poultry



EUROWEIGH MULTIHEAD RANGE
M1400 (5L Bucket)



TARGET
PACKAGING
SYSTEMS LTD

PRECISION QUALITY RELIABILITY

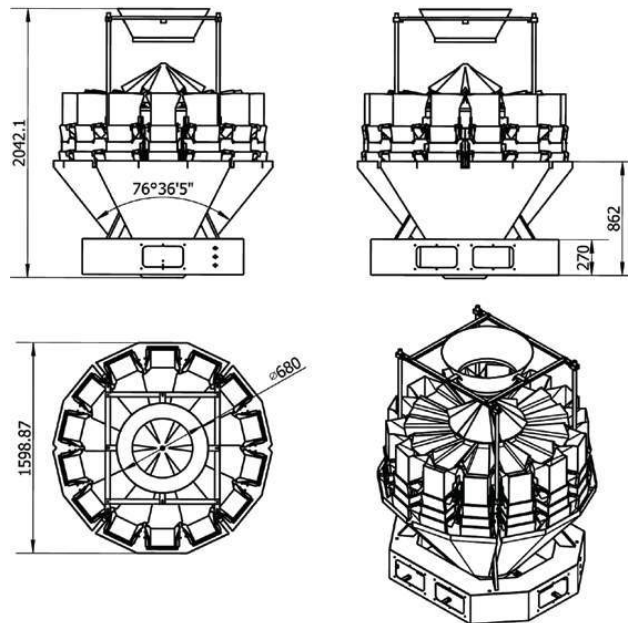

Features

- Program recovery function can reduce operation failures
- No products auto pause function can improve weighing stability and accuracy
- High-precision digital load cell
- User friendly help menu touch screen contributes to easy operation
- 100 program capacity can meet various weighing requirement
- 15 languages available for global markets
- Linear amplitude can be adjusted independently
- Suitable for products with Max 200mm length.
- Special rotary top cone dispense products evenly to each linear feeder pan.
- 60° steep discharge chute makes sure products discharge is acted smoothly.

Optional Extras

Dimple plate, Timing Hopper, Printer.

Technical Data

M1400 (5L Bucket)	
Monitor	10.4" HMI English Touch Screen
Packing Speed	up to 40 bags / min
Hopper Speed	5 Litre
Power Supply	220V / 1500W / 50Hz / 60Hz / 10A
Air Consumption	0.2M ³ /min, 0.6Mpa
Top Cone	Rotary Top Cone
Weighing Accuracy (g)	100 - 3000g
Machine Dimensions	1800(L) x 1380(W) x 2000(H)



EUROWEIGH MULTIHEAD
M1400 - (5L Bucket)